

PRODUCT BULLETIN

Features & Benefits:

- Guaranteed 100% kill of infestation
- Eliminate chemical fumigants: average ROI of 9 months
- Easy set up and operation: adjust process while operating
- Gravity or blow through processes without space consuming auxiliary equipment
- SQF Safe Quality Food Certification

The Infestroyer® is an impact mill specifically designed for the flour industry. Foreign insects entering food products must be eliminated with a 100% kill rate while preserving the particle size of the flour to maintain size and color. The Infestroyer® delivers on this commitment by offering a rugged impact mill that effectively eliminates adult insects, larva and eggs from flour products. The Infestroyer® combines easy cleaning with low maintenance, there are no screens to clog and impact areas offer quick access. The Infestroyer® is available in USDA type design, including 316 stainless construction, without certification which saves money while offering a feature rich design.

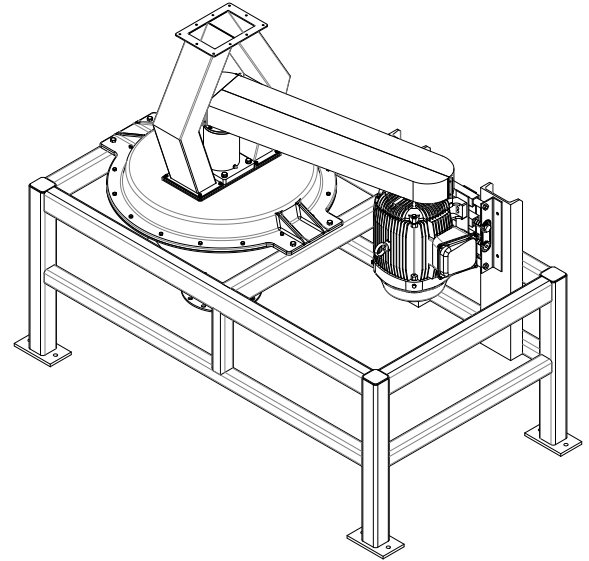

Capacity Range: 2.5-75 TPH
 Motor Power Range: 5-150 HP

How it Works:

Infested flour enters the top of the Infestroyer® through a feed chute, either by a feeder device or a blower. The infested material drops onto a spinning horizontal rotor. Centrifugal force throws the infested flour through a set of vertical impact pins that are concentrically mounted to the rotor. Once the infested material makes contact with the pins and the impact wall the insects, larvae and eggs are instantly killed and disintegrated without grinding the materials. The unground flour next spirals out of the bottom of the mill for collection in a bin or silo where a scourer or aspirator can easily separate the materials.

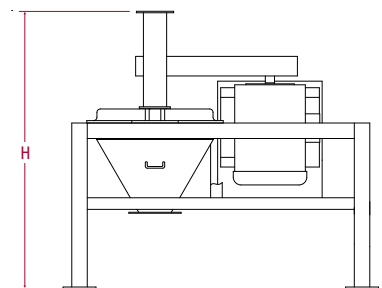
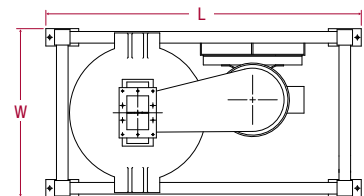

Options:

Product Contact Parts:

- 304 Stainless Steel
- 316 Stainless Steel

Applications:

- Wheat and Corn Flour
- Bakery Mixes
- Corn Meal
- Semolina

INFESTROYER®

MILL SIZE	MAX. MOTOR POWER RANGE (HP)	TONS PER HOUR	APPROXIMATE WEIGHT		OVERALL DIMENSIONS L x W x H	
			(LBS)	(KG)	(IN)	(MM)
#15 Infestroyer	5 - 15	2.5 - 7.5	525	238	60" x 31" x 50"	1524 x 787 x 1270
#20 Infestroyer	20 - 60	10 - 30	2,200	998	72" x 36" x 72"	1829 x 914 x 1829
#40 Infestroyer	75 - 150	37.5 - 75	5,350	2,427	102" x 52" x 82"	2591 x 1329 x 2083

Measurements are for general reference only. Please consult dimensional drawings for exact measurements.