

### PRODUCT BULLETIN

### Features & Benefits:

- Saves on operating expenses with low energy consumption
- Reduce capital cost: Eliminate the need for auxiliary equipment such as cyclones, dust collectors, air locks or system fans
- Easily select fine particles as the desired product or de-dust coarse products
- Higher capacity and finer separations than screeners with no blinding
- Built to last: Tough, durable construction means low maintenance

The Whirlwind® Air Classifier incorporates a self-contained fan and rejector blade classification system. Its internal fan design does not require cyclones, air locks or dedicated baghouse for product collection of particles in the range of 100 to 400 mesh. Offering a significantly smaller footprint than screening separation and much lower capital cost, the Whirlwind® is designed to process a wide variety of materials. Typical Whirlwind® applications include aggregates, animal proteins, crushed stone, ceramics, diatomaceous earth, flyash, food products, gypsum, metals, frac sand, silica sand, soda ash and more.

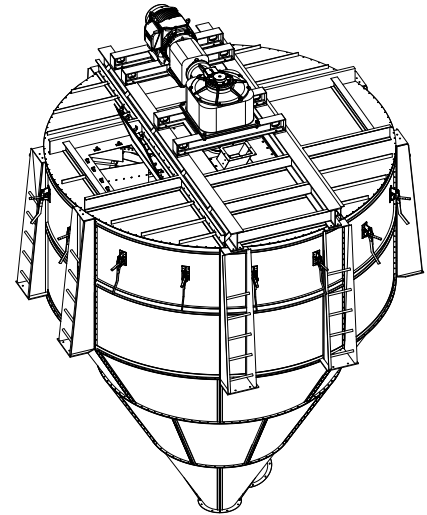

### How it Works:

Material is fed into the top of the Whirlwind® Air Classifier through the feed inlet and falls onto the rotating distributing plate. Centrifugal force sends the materials onto the lower distributing plate for even distribution into the airflow. Due to gravity, the larger particles settle into the coarse cone and finer particles are swept upward into the whirling selector blades for further classification. During the secondary separation, oversized particles are spun out of the air flow and drop down into the coarse cone. The selected fines continue through the circulating fan and into the fines cone. Fines drop out of the recirculated air flow by gravity at the fixed return air vanes.

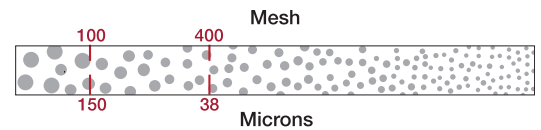
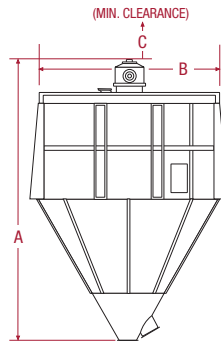

Product Fineness: 100 mesh (150 µm) - 400 mesh (38 µm)  
 Feed Capacity: 1 - 1000 TPH

### WHIRLWIND® AIR CLASSIFIER

MODEL	HP	AIR FLOW VENT (CFM)	FEED RATE (TPH)	APPROXIMATE WEIGHT		HEIGHT A		DIAMETER B		MIN. CLEARANCE C	
				(LBS)	(KG)	(FT)	(MM)	(FT)	(MM)	(FT)	(MM)
20"	5 - 7.5	25 - 50	1	650	295	3' 9"	1143	2' 5"	737	1' 9"	533
3'	7.5 - 10	65 - 125	3	1,500	680	6' 7"	2007	3' 3"	991	3' 0"	914
4.5'	10 - 15	75 - 150	8	2,400	1089	8' 8"	2642	4' 10"	1473	3' 0"	914
6'	15 - 25	90 - 175	14	6,800	3084	10' 9"	3277	6' 4"	1930	3' 8"	1118
8'	20 - 30	150 - 300	25	9,500	4309	13' 0"	3962	8' 4"	2540	4' 8"	1422
10'	30 - 40	190 - 375	40	13,000	5897	15' 8"	4775	10' 4"	3150	4' 8"	1422
12'	40 - 50	275 - 550	56	18,500	8392	19' 1"	5817	12' 4"	3760	5' 6"	1676
14'	50 - 75	400 - 800	77	21,500	9752	21' 1"	6426	14' 5"	4394	5' 6"	1676
16'	100 - 150	675 - 1,350	125	31,000	14061	24' 5"	7442	16' 5"	5004	6' 3"	1905
18'	250 - 300	1,000 - 2,000	200	50,000	22680	27' 7"	8407	18' 5"	5613	8' 9"	2667
20'	350 - 400	1,500 - 3,000	300	68,000	30844	30' 9"	9373	20' 5"	6223	9' 0"	2743
22'	450 - 500	2,000 - 4,000	450	87,000	39463	33' 0"	10058	22' 5"	6833	9' 0"	2743
24'	600 - 700	2,500 - 5,000	600	117,000	53070	35' 10"	10922	24' 5"	7442	10' 9"	3277
26'	600 - 800	3,000 - 6,000	800	125,000	56699	38' 9"	11811	26' 5"	8052	10' 9"	3277

Measurements are for general reference only. Please consult dimensional drawings for exact measurements.

### Applications:

- Aggregates
- Animal Proteins
- Ceramics
- Chemicals
- Coal
- Crushed Stone
- Diatomaceous Earth
- Flyash
- Food Products
- Gypsum
- Hydrated Lime
- Minerals
- Metals
- Frac Sand
- Silica Sand
- Soda Ash
- Sodium Bicarbonate