

PRODUCT BULLETIN

Features & Benefits:

- Industry's lowest HP use, saving energy and money
- Abrasion resistant wear parts to minimize down time
- Advanced wet or dry cleaning system to maximize up-time
- Finest cuts, narrow PSD range
- Cooling technology prevents premature expansion of sorbents
- Performs in any climate

The Simpactor® FGT pin mill reduces sorbent particle size, improving the emissions of coal fired power plants, industrial boilers, municipal furnaces and bio-mass plants. The FGT Series mills decrease operating and disposal costs through decreased sorbent usage and provide utilities with an efficient and economical method for emissions control. Sturtevant FGT Series mills are specifically designed for the rigors of dry sorbent processing and provide companies with the most reliable and efficient technology to meet their demands.

How it Works:

Dry sorbent materials enter the top of the Simpactor® FGT pin mill through a feed chute using a blower, then pass down either side of the external columns onto a spinning horizontal rotor. As the material hits the rotor, centrifugal force throws the powder through a series of vertical impact pins that are concentrically mounted to the rotor causing the particles to smash apart on impact. The finely ground particles next hit an angled impact wall and spiral out the bottom of the mill for collection.

Applications:

- Trona
- Sodium Barcarbonate
- Hydrated Lime
- Mercury Control

Options:

- Controls
- Closed Loop Cooling System
- Dry cleaning
- Skid packages

SIMPACTOR® FGT

MILL SIZE	MOTOR POWER RANGE (HP)	TRONA CAPACITY AT D50=5 – 10µM (TPH)	SBC CAPACITY AT D50=10 – 20µM (TPH)	SBC CAPACITY AT D50=6 – 18µM (TPH)	APPROXIMATE WEIGHT		OVERALL DIMENSIONS L X W X H	
					(LBS)	(KG)	(IN)	(MM)
#3C-18.5-FGT	30 - 40	1.5 - 2	0.1 – 1	.01 – 2	1,992	904	33" x 70" x 45"	838 x 1778 x 1143
#6C-30-FGT	75 - 125	2 - 6	2 - 4	2 - 6	5,025	2279	106" x 49" x 87"	2692 x 1245 x 2209
#9C-40-FGT	200 - 300	6 - 9	5 - 8	6 - 8	10,000	4536	96" x 60" x 102"	2438 x 1524 x 2591

Measurements are for general reference only. Please consult dimensional drawings for exact measurements.

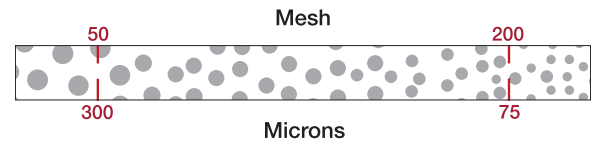
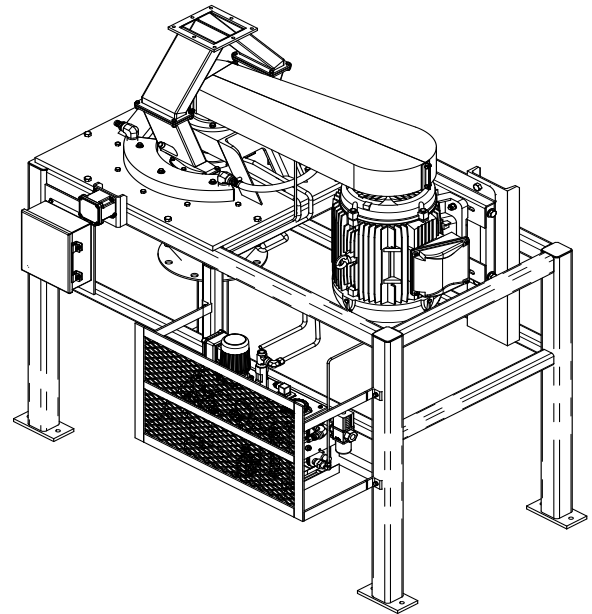

Product Fineness: d50 = 15-20 µm
 Capacity Range: .01-9 TPH
 Motor Power Range: 30-300 HP

