

PRODUCT BULLETIN

Features & Benefits:

- Unique dust free design captures and contains fugitive dust
- Space saving design
- Long wear life: hardened impact pins sleeved with Tungsten Carbide
- High air flow for cool operation
- Economical: low energy consumption with high throughput
- Tight particle size control

The Simpactor® BVM has a unique space saving design perfect for gravity fed applications where space is at a premium. Large and expensive auxiliary equipment, such as vented bin hoppers, vented screw augers or cyclones with suction fans are no longer required. The exclusive dust free design lets air out through the vents at the top, not the bottom of the mill, allowing the Simpactor® BVM to operate without the standard vented collection bin. Materials exit the mill non-aerated preserving the milled fines created by the milling process.

How it Works:

Materials enter the top of the Simpactor® BVM through a feed chute and drops it onto a spinning horizontal rotor. As the material hits the rotor, centrifugal force throws the powder through a series of hardened impact pins, sleeved with tungsten carbide that are concentrically mounted to the rotor, causing the particles to smash apart on impact with the pins. The finely ground particles next hit an angled impact wall and spiral out the bottom of the mill for collection. Air flow is vented upwards through integral bin venting that is pulsed causing all the fine particles to drop down the mill walls and join back with the exiting milled product.

Applications:

- Limestone (3% or less silica)
- Gypsum (3% or less silica)
- Zeolite (3% or less silica)
- Bauxite
- Clay (3% or less silica)
- Green Ceramics (non-fired)
- Tungsten

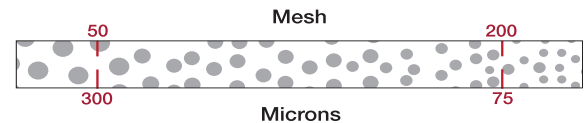
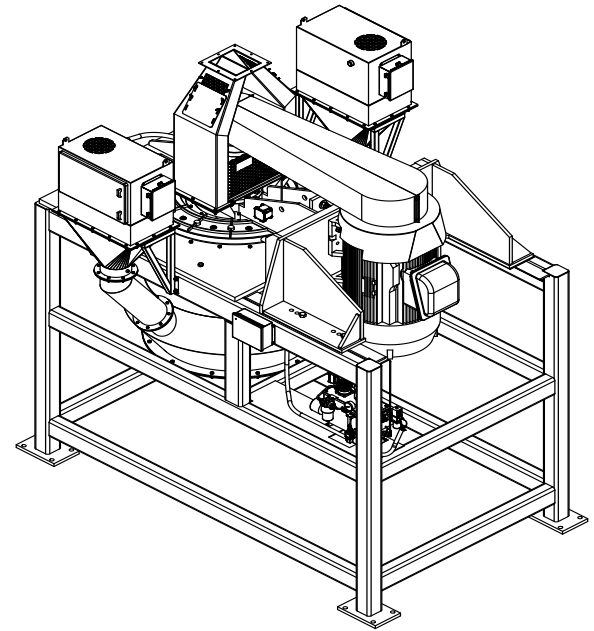

Product Fineness: 50 mesh (300 µm)-200 mesh (75 µm)
 Capacity Range: 4 - 30 TPH
 Size Range: 25 - 300 HP

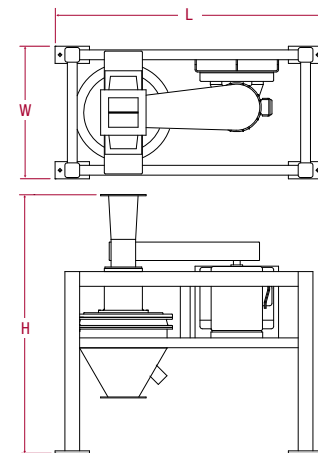

MILL SIZE	MOTOR POWER RANGE (HP)	TONS PER HOUR	APPROXIMATE WEIGHT		OVERALL DIMENSIONS L x W x H	
			(LBS)	(KG)	(IN)	(MM)
#3-16-BVM Simpactor	25	4	1,500	206	54" x 26" x 52"	1372 x 660 x 1321
#6-26-BVM Simpactor	125	10	4,700	2132	72" x 36" x 70"	1829 x 914 x 1778
#9-40-BVM Simpactor	300	30	11,000	4990	96" x 60" x 102"	2286 x 1524 x 2591

Measurements are for general reference only. Please consult dimensional drawings for exact measurements.