

PRODUCT BULLETIN

Features & Benefits:

- Documentation to support FDA validation (IQ/OQ/PQ)
- Consistent tight PSD for better suspension, dispersion & absorption
- Easily disassembles by hand, without tools for cleaning and sterilization
- Contamination free design
- Mills to nano-particle size
- No heat build-up: processes heat-sensitive materials

The Sanitary Micronizer® is the world's most popular jet mill listed by the USDA for the production of materials such as active pharmaceutical ingredients and biological products. The Micronizers® open design allows complete access to the internal material grinding chamber and compressed air chamber for easy cleaning, product changeover or sterilization. Designed for high performance which surpasses the economical fineness limit of many mechanical grinders, the Micronizer® can consistently produce particles as small as 0.25 microns with guaranteed results.

How it Works:

The Sanitary Micronizer® utilizes a fluid energy—compressed air or gas—grinding system which rapidly expands gas to generate a high-speed rotation of material. This creates near sonic particle-on-particle impact, generating increasingly smaller fines. Centrifugal force holds larger particles in the grinding rotation area until they have achieved the desired fine particle size. Centripetal force drags the desired particles towards the static classifier where they are allowed to exit upon achieving the correct particle size.

SANITARY MICRONIZER®

MILL SIZE	AIR COMPRESSOR SIZE ¹ Compressed Air SCFM (SCMH)	² bHP	CAPACITY LBS/HR (KG/HR)
Qualification	8 (13.6)	2	1/8 – 1 (.05 – .5)
2"	20 (34)	5	1/2 – 2 (.2 – .9)
4"	55 (93.5)	13	2 – 40 (.9 – 18)
8"	130 (221)	31	10 – 100 (4 – 45)
12"	260 (442)	62	30 – 250 (13 – 113)
15"	350 (595)	83	50 – 300 (22 – 136)

¹-Volume of free air at 60°F (16°C), 14.7 psi compressed to 100 PSIG. Includes air consumed by feed injector nozzle.

²-Brake HP necessary to generate 100 PSIG compressed air.

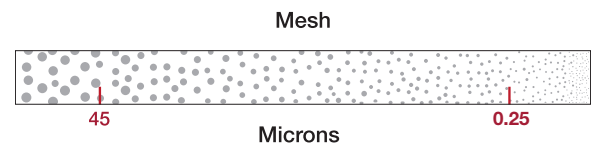
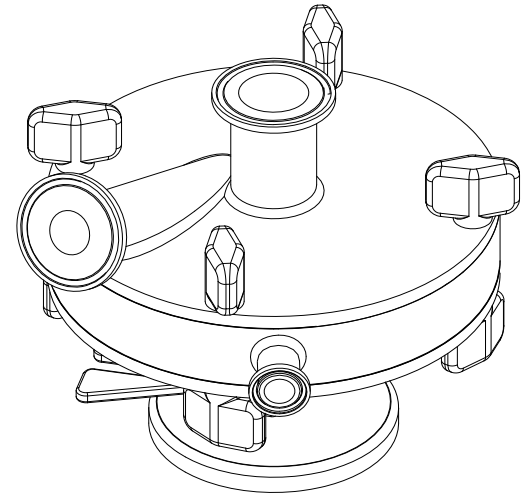

Product Fineness: 45 µm - 0.25 µm
 Capacity Range: 1/8-300 lbs/hr (.05-136 kg/hr)
 Compressed Air Requirements: 8-350 SCFM @100 PSIG
 (13.6-595 SCMH @ 100 PSIG)

Applications:

- Pharmaceutical
- Food Additives
- Excipients
- Nutraceuticals

Liner Options:

- Wear Resistant Liners
- 316 Stainless Steel
- ShieldOx

Accessories:

- Feeders
- Baghouse
- Sanitary Product Collector