

PRODUCT BULLETIN

Features & Benefits:

- Guaranteed TiO₂ dispersion of agglomerates
- Available with operation by high pressure steam, hot air or ambient
- Proprietary wear protection system cuts operating costs by 60%
- Contamination free design with easy-clean features

The Steam Micronizer[®] is used worldwide in hundreds of TiO₂ production lines because it performs the most efficient and economical deagglomeration for the ultimate performance in dispersion, opacity, tint strength and a variety of additional benefits to both appearance and performance. Powered by steam, the Micronizer[®] is ideally suited for deagglomeration and particle size reduction of inorganic pigments.

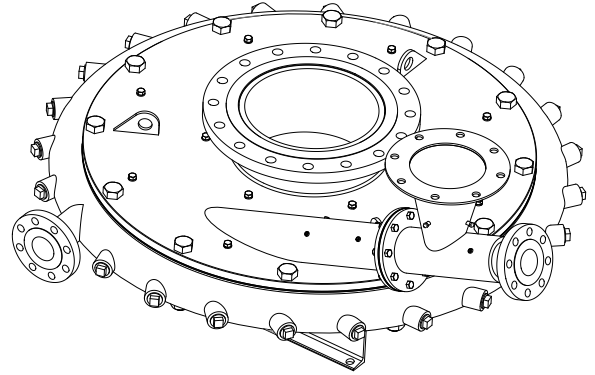

How it Works:

To use a Steam Micronizer[®], superheated steam, at high temperature and at high pressure is applied to both the feed portion and grind portion of the machine. Steam energy applied to the grind portion produces a rapidly rotating vortex in the grinding chamber. Agglomerated titanium dioxide feed material is propelled into the grinding chamber, by the feed portion tangent to the rotating steam, where it becomes caught in the vortex and rotates with it. Particle-on-particle impact size reduces (breaks apart) the material. Centrifugal force keeps the larger particles rotating in the stream for further size reduction until their mass becomes small enough to move toward the center of the Micronizer[®] where they leave the Micronizer[®] with the exiting flow of steam. The particles may be collected as low micron and sub-micron finished product or passed on to the next stage in a manufacturing process.

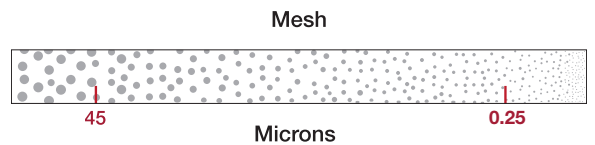

Product Fineness: 45 μm - 0.25 μm
 Capacity Range: 10-10,000 lbs/hr (4-4536 kg/hr)
 Super-Heated Steam Requirements:
 325-8,000 SCFM @150 PSIG

Sturtevant offers various liners, including the exclusive PureLine liner that is specifically designed for the milling of TiO₂. Research indicates that there is an optimum hardness that prevents wear and the PureLine liner has been proven to last twice as long as ceramic liners and at a third of the price.

Applications:

- Titanium Oxide (TiO₂)

Liner Options:

- PureLine™
- ShieldOx™
- ArmorLine™

STEAM MICRONIZER[®]

MILL SIZE	SUPER-HEATED STEAM at 550°F (288°C) and minimum 150 PSIG.	CAPACITY LBS/HR (KG/HR)
4"	140	2 - 40 (.9 - 18)
8"	325	10 - 100 (4 - 45)
15"	900	50 - 300 (22 - 136)
20"	1250	100 - 1000 (45 - 453)
24"	2500	250 - 1400 (113 - 635)
30"	4000	600 - 3000 (272 - 1360)
36"	6000	1000 - 6000 (453 - 2721)
42"	8000	2000 - 10,000 (907 - 4536)

Accessories:

- Screw Feeders
- Baghouse
- Filters
- Sound Enclosure
- Steam Condenser